



LA GARDE
INOX

**DON'T CUT
CORNERS**



THE QUEST FOR QUALITY, FROM GRAPE TO TANK

The grapes are treated with utmost care; they are the primary ingredient, without which there simply would be no wine. However, the tank that welcomes your precious harvest also deserves special attention in order to help yield the full expression of the richness of the fruits.

In this regard, the stainless steel fermentation tanks by La Garde Inox combine the latest technological advancements and the expertise of SML Inox with the fruits of a millennia-old tradition. Featuring a unique design and incomparable characteristics, La Garde Inox tanks enable a higher degree of care and precision to working with grapes.

The tanks' original cubic shape not only adds value to the winemaking process but also results in space savings of at least 22% compared to traditional tanks, thereby providing the potential to produce more wine within the same cellar area.

Environmentally friendly, La Garde Inox tanks reduce the demand for water, cleaning products, and energy needed for cleaning, while also generating less waste.

La Garde Inox designs and customizes tanks according to the specific needs of cellar masters, using advanced technological tools such as robotics, computer-aided design and laser cutting. The tanks are then meticulously hand-assembled, resulting in unparalleled quality and finish.

La Garde Inox produces various models of tanks ranging from 500 US gallons to 7200 US gallons. We design closed top freestanding and stackable models in addition to hybrid and variable capacity tanks. The aesthetics of La Garde Inox tanks are a source of pride for any winemaker who not only aspires to the highest standards of quality but the creation of exceptional wines.



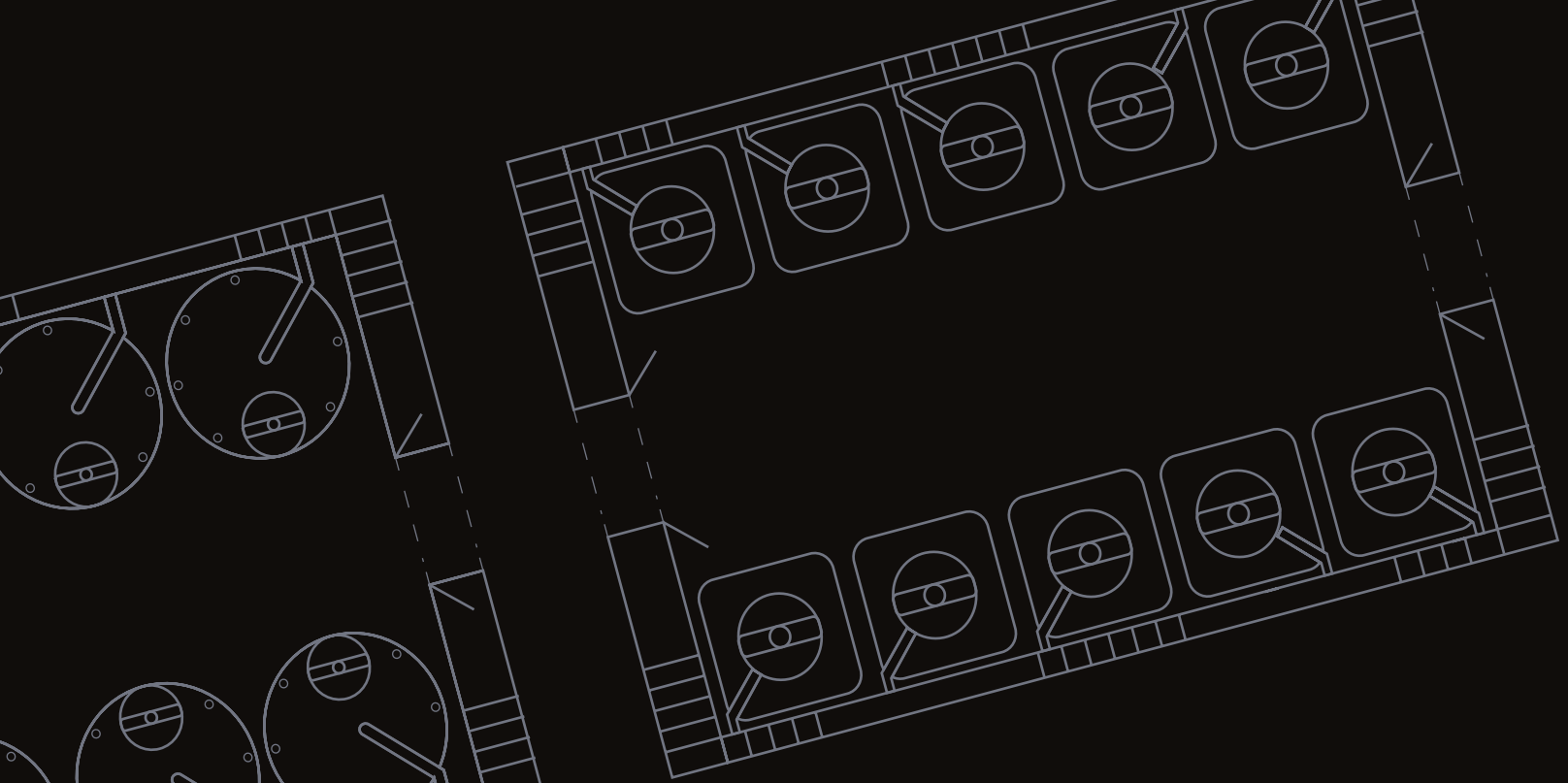

01

SPACE OPTIMIZATION

The distinctive shape of our tanks enables enhanced production by efficiently utilizing the space in your cellar. In terms of equivalent area, La Garde Inox tanks provide space savings of at least **22%**.



02

ENVIRONMENTALLY-FRIENDLY

Every weld on both exterior and interior surface undergoes meticulous hand-polishing. This method guarantees a surface finish of exceptional quality that aligns with the highest standards.

Thanks to our efficiency expertise, we accomplish remarkable savings of **up to 90%** in water and chemicals during the cleaning process. Moreover, our pioneering methodology facilitates a noteworthy reduction in cleaning time—resulting in a **50% decrease** compared to conventional methods.

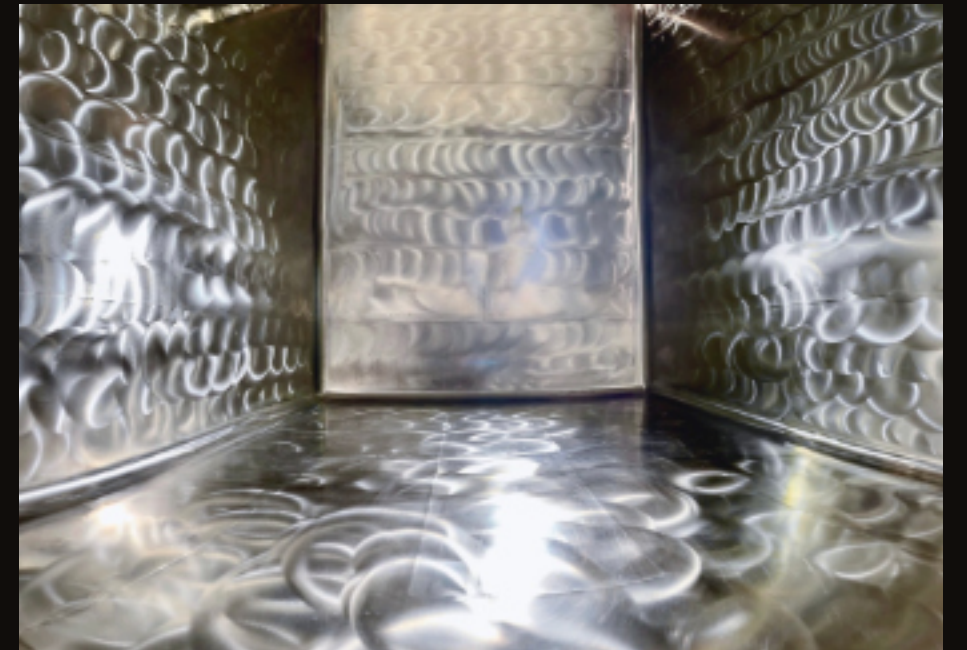



03

OPTIMIZED EXTRACTION

Due to their cubic and rectangular shape, La Garde Inox tanks increase ope, thereby optimizing the extraction of tannins from the grapes.

The distinct shape of our tanks enhances the contact area between the pulp, skin, and grape juice by a **minimum of 25%**. In addition, the robust belts surrounding our tanks are designed to hold glycol, which enables the content of the tanks to be kept at a desired temperature. This creates the ideal environment for optimal fermentation.

GREATER CONTACT AREA

- Enhanced tannin extraction
- Improved pump over
- Elevated wine quality

THINNER GRAPE CAP

- Easier execution of punch-downs

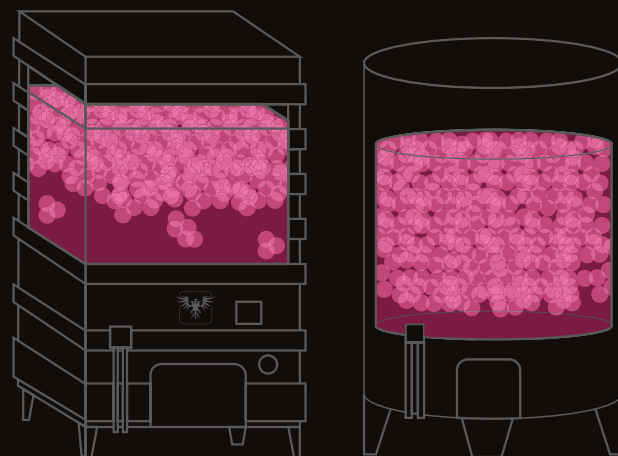

04

EXCEPTIONAL TEMPERATURE CONTROL

By choosing thicker stainless steel and glycol-based temperature regulation belts, we ensure improved thermal conductivity and enhanced temperature control. This enhancement in thermal control can lead to energy savings of up to 50%.

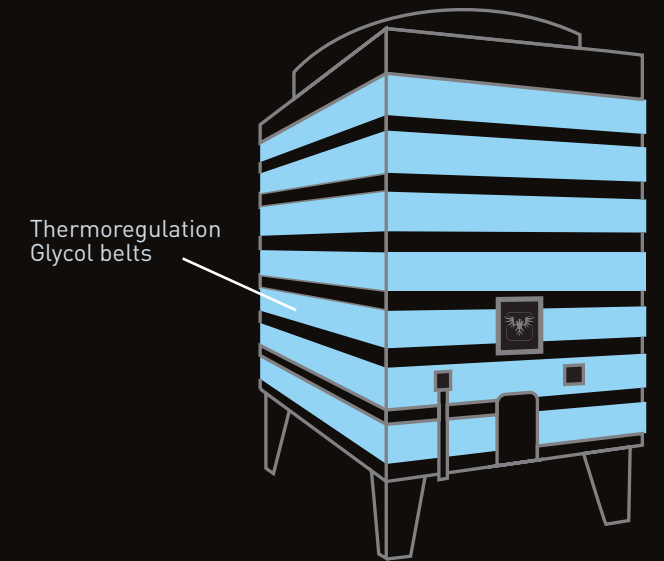

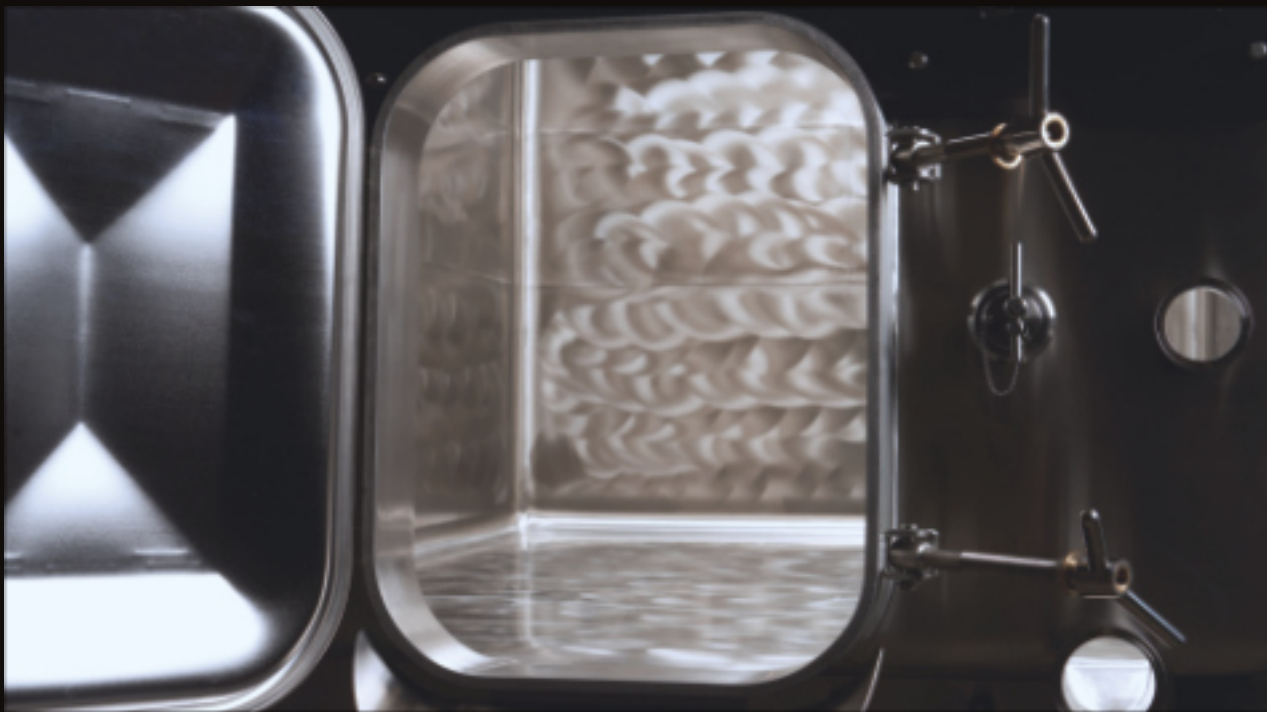

05

AESTHETICS

Every one of our tanks undergoes meticulous hand-polishing, rendering any welds invisible both inside and outside.

The refined design not only satisfies the requirements of the most esteemed wineries but also mirrors the dedication and artistry invested in the crafting of your creations.



CLOSED TOP TANKS

Our closed top tanks are equipped with rectangular autoclave-type doors at the front. The bottom of our tanks are inclined, allowing for a better flow with a flanged connection to ensure efficient drainage and complete cleaning. Each tank is fitted with glycol thermoregulation belts, which ensure optimal temperature control. The special hand polished finish on the interior of the tank, as well as all polished welds on our tanks, enable easy and efficient cleaning.

500	660	750	900	1200	1500	1800	2100	2400	3000	3600	4800	6500	7200
X	X	X	X	X	X	X	X	X	X	X	X	X	X



STACKABLE CLOSED TOP TANKS

In order to fulfill the requirements of ambitious winemakers aiming to optimize their space, La Garde Inox has created an innovative stackable wine tank. This exceptional design allows for efficient utilization of space without compromising on quality. Offered in two convenient sizes, 500 and 660 US gallons, it provides a flexible and elegant solution for winemaking.

500	660
x	x





OPEN TOP TANKS

Our open top fermenters are available with or without lids. They feature a rectangular autoclave-type door and each of them is fitted with glycol thermoregulation belts which ensure optimal temperature control. The bottom of the tanks are inclined, allowing for a better flow and a flanged connection to ensure efficient drainage and complete cleaning. They offer the same exceptional finish as our closed tanks, with polished interior and exterior welds making cleaning very easy.

500	660	750	900	1200	1500	1800	2100	2400	3000	3600	4800	6500	7200
X	X	X	X	X	X	X	X	X	X	X			

***Open-top tanks don't have a manway and hybrid-top tanks have a standard center manway.



VARIABLE CAPACITY TANKS

La Garde has developed cylindrical variable capacity tanks which are adapted to the market needs. They possess innovative features that simplify their handling, emptying and cleaning. A flanged connection at the front in addition to a sloped bottom allows for a better emptying flow. In addition, a swivel arm, on ball bearings with pulleys, allows for the lid to be easily lifted.

500	660	750	900	1200
x	x	x	x	x

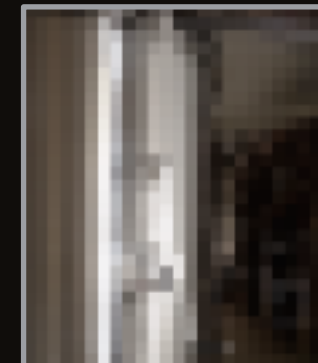



BARRELS

La Garde Inox barrels have a capacity of 75 US gallons, or 284 liters, and are made of 304-grade stainless steel. Their dimensions are 25.5 inches wide and 37.9 inches tall. To facilitate transportation and handling, they are equipped with a carrying handle at each end.



STANDARD FEATURES



RECTANGULAR AUTOCLAVE DOOR

Smaller tanks of 500 and 660 US gallons feature vertical doors measuring 17"x22", while larger tanks of 750 US gallons and above have horizontal doors measuring 22"x17". Positioned at the bottom center of the tank with a fixed lip, the rectangular door allows easy access for maintenance and inspection.



THERMOREGULATION BELTS

Optimize temperature control in your tanks with our thermoregulation belts. Suitable for all tank sizes, they offer easy connection for the inflow and outflow hoses of cooling liquids.



TASTING TAP

The tasting tap facilitates effortless extraction of product samples. Its placement varies based on the tank size, ensuring optimal access for quality control purposes.



12" THIMBLE TEMPERATURE SENSOR

·500 to 2400 US gallons have 2 thimbles: 1x front / 1-x back
·3000 to 7200 US gallons have 3 thimbles : 1x front / 2x back

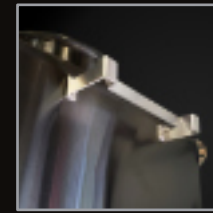

BUILT-IN LADDER SUPPORT

The integrated ladder support, located at the center of the top front face of the tank, guarantees secure and straightforward access for maintenance purposes.



ATTACHMENT FOR ACCESSORIES

Our tanks are equipped with standard attachment, providing flexibility for future accessory additions. Specifically designed for:

- Support for temperature controller
- Grommet tubes for temperature controller cables
- Pump-over pipe



SLATE TO TAKE NOTES

An acrylic slate for taking notes, mounted on a stainless steel bracket, is located to the right of the rectangular door, enhancing your workflow.

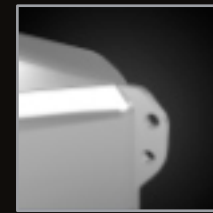

OPTIMIZED TRANSPORT: EASY AND SECURE HANDLING

Our wine tanks are equipped with lifting lugs, ensuring easy and secure transport. Furthermore, they are designed and reinforced to be transported by the base with a forklift.

CONVERSION CHART

(CLOSED TOP OVERALL WITHOUT LEGS)

US GAL.	TON OF GRAPES	HECTO-LITERS	CUBIC FEET	CUBIC METERS	LENGTH	WIDTH	HEIGHT	WEIGHT	SQ. FT. / FLOOR
500	1.7 t	18.92	66.8	1.89	42"	68"	66"	1150 lbs	20.0
660	2.2 t	24.98	88.2	2.50	48"	68"	73"	1200 lbs	22.7
750	2.5 t	28.38	100.3	2.84	50"	72"	81"	1300 lbs	25.0
900	3.0 t	34.07	120.3	3.41	50"	75"	92"	1400 lbs	26.2
1200	4.0 t	45.42	160.4	4.54	55"	80"	101"	1500 lbs	30.6
1500	5.0 t	56.78	200.5	5.68	59"	82"	111"	1800 lbs	33.8
1800	6.0 t	68.14	240.6	6.81	64"	91"	109"	2000 lbs	40.6
2100	7.0 t	79.49	280.7	7.95	69"	96"	111"	2200 lbs	46.3
2400	8.0 t	90.85	320.8	9.08	69"	93"	127"	2400 lbs	44.9
3000	10.0 t	113.56	401.0	11.36	74"	100"	132"	3200 lbs	51.7
3600	12.0 t	136.27	481.3	13.63	78"	109"	135"	3500 lbs	59.4
4800	16.0 t	181.70	648.4	18.93	96"	121"	130"	5100 lbs	81.3
6500	21.7 t	246.05	869.0	24.60	102"	127"	159"	6500 lbs	90.4
7200	24.0 t	272.55	962.5	27.25	109"	125"	166"	7500 lbs	95.4



OPTIONS

01 MANWAY POSITION
Our manways are located on the top of the tank, providing Front (F), Center (C) or Back (B) access according to your setup.

02 MANWAY DIAMETER
Select the ideal Manway diameter for your tank. Choose from options of 24" and 32" to adapt your winemaking process to your requirements. Improve accessibility and efficiency in your winery.

03 REMOVABLE FALL PROTECTION GRID FOR MANWAY.
Choose between a 24" or 32" grid, designed to prevent large objects from falling into the tank. The brackets are welded on the inside for a secure installation.

04 FRONT OVAL DOOR
Select the right oval door for your tanks. Options for the tanks range from 900 to 7200 US gallons
· 17"x12"
· 21"x17"

**Only 17" x 12" for 500 to 750 Us Gallons.

05 LIP HEIGHT
The measurement of the tank's leg height is taken beneath the fixed lip of the rectangular door. This measuring approach ensures that your equipment will fit under the door during required activities. This meticulous attention guarantees a smooth incorporation of the tank into your production process.

Lip height options: 12", 24", 30", 32", 36", or 48".

06 DRAINING PORT
Choose from 2", 3", or 4" drain port options to match your equipment. Designed for draining the tank, the port is positioned at the bottom right corner.

07 RACKING PORT
Select a 2" or 2-1/2" diameter racking port for your tank, strategically positioned to the right of the rectangular door. For larger tanks, 750 US gallons and above, the racking port aligns with the sampling faucet, ensuring a seamless design that meets your

08 AIR MIXING PORT
Located underneath the tank, our air mixing port features four 1-1/2" diameter tubes with tri-clamps on both sides. This system allows for gentle and efficient air bubble mixing and agitation, enhancing the quality and consistency of your winemaking process.

09 BASE THERMOREGULATION BELT
Our base thermoregulation belt, installed between the bottom panel and the base grid, offers an additional layer of insulation. Combined with cooling liquid pipes, it provides a significant advantage for precise temperature control, contributing to the quality and consistency of your wine.

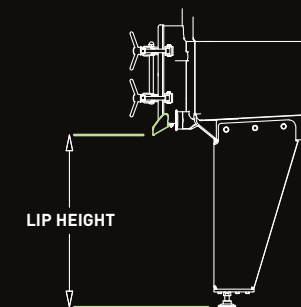

ACCESSORIES

01 REMOVABLE HYBRID TOP
The assembly of the removable lid enables the conversion of an open tank into a closed one.

02 LADDER
Custom- made ladders designed to fit the wine tank.

03 SUPPORT FOR TEMPERATURE CONTROLLER
To accommodate your temperature control system, our support will be mounted on the left side of the first cooling belt. ***controller not included

04 STAINLESS TUBING FOR CONTROLLER WIRING
Two tubes are provided for the cables of the temperature controller and temperature sensors. These tubes are located on the left side of the tank, just beneath the first thermoregulation belt.

05 1" NPT INTERCONNECTION FOR THERMOREGULATION
A 1" NPT flexible stainless steel hose interconnects the thermoregulation belts in series, reducing the glycol hoses connecting the refrigeration unit to the tank to just two.

06 ANALOG THERMOMETER
Analog thermometer for 12" thimble.

07 PUMP OVER PIPE
The pump-over pipe pumps wine from the tank's bottom to the top for better aeration and blending. Positioned in the lower corner, it ascends through the access door (tri-clamp included).

08 IRRIGATOR FOR PUMP OVER SYSTEM
The irrigator is a spray arm crafted to attach to the end of the pump-over pipe. Its purpose is to evenly disperse the liquid within the tank while circulating the wine using the pump-over pipe.

09 VENTURI AERATOR ON PUMP-OVER
The Venturi aerator is designed to connect to the racking column to infuse air into the wine when using the pump-over pipe.

10 BALL VALVE
You have the option to choose between 2" or 3" (O-ring and tri-clamp included). The ball valve is intended for attachment to either the draining port or the racking port.

11 360° ROTATIONAL HIGH PRESSURE WASHING BALL
A 360° rotational high-pressure washing ball with a 2" diameter connector is included (O-ring and tri-clamp included). It is designed to be installed on the end of the pump-over pipe inside the tank for cleaning purposes.

12 CONCENTRIC REDUCER
A concentric reducer is used to connect to a pipe with a different diameter from the port from which the product is extracted. Options are:
·2-1/2" -> 2" reducer
·3" -> 2" reducer

13 ROTATING RACKING ARM
The rotating racking arm with a 2-1/2" diameter has been designed to extract the liquid in the tank down to its lowest level.

14 TASTING TAP SCREEN
This screen specifically covers the tasting tap and is commonly used on 500 US gallon tanks.

15 SCREEN WITH ROUND HOLES (RACKING AND DRAINING PORT)
Screens with circular holes are provided for the racking and draining ports, ensuring proper separation of materials. *(Note that these screens cannot be used when filling the tank through the draining port).

16 SCREEN WITH ROUND HOLES (RACKING PORT)
These screens with circular holes are intended to be used during filling through the drainage port.





SML InOX is a family-owned company founded in 1966. With the expertise and dedication of our team of 175 exceptional employees, we design robust and durable stainless steel products.

We have succeeded in expanding our operations across North America, spanning from coast to coast, covering regions from the Caribbean to the Arctic Circle and all the way to New Zealand. In addition to providing kitchen equipment, we have developed our fermentation tank division, La Garde InOX, to meet the needs of the wine industry. We have also strengthened our presence in Original Equipment Manufacturing (OEM) and precision equipment manufacturing for the pharmaceutical and biopharmaceutical industry.

SML InOX is driven by the belief that our commitment to excellence can contribute to significant advancements in various fields. We take pride in knowing that our skills can be used to support scientific research, enhance travel experiences, and assist award-winning chefs in creating memorable and vibrant dishes.

CAPTURE STAINLESS

We are motivated by the prospect of being an integral part of our customers' success and helping them achieve their most ambitious goals. Ultimately, what drives SML InOX is the realization that our work can make a meaningful difference in people's lives and the world around us.

It started with an ambitious idea to create stainless steel products that are robust, durable without compromising on elegance and refinement. Today, inhabited by the ancient legend of the white deer as our corporate image suggest, we are more ready than ever to rise to the challenge. Our recipe for success is simple: integrity, agility, know-how, inventiveness and efficiency. With every new path we take, we remain true to our roots, our history and our heritage.

We are motivated by excellence, it is what guides our every move and our quest for perfection is accompanied by the thrill derived from constantly surpassing ourselves. We do this with one unique goal in mind ... to capture stainless!



lagardeinox.com
info@lagardeinox.com

1 800 263-5170



bvnorthamerica.com
bvna@buchervaslin.com

707 823-2883

lagardeinox.com



Contact Our Experts



La Garde Inox,
A division of SML Inox

5170, rue Rideau, Québec Qc G2E 5S4 Canada



1200 USG
lagardeinox.com